

CONNECTION DIAGRAM

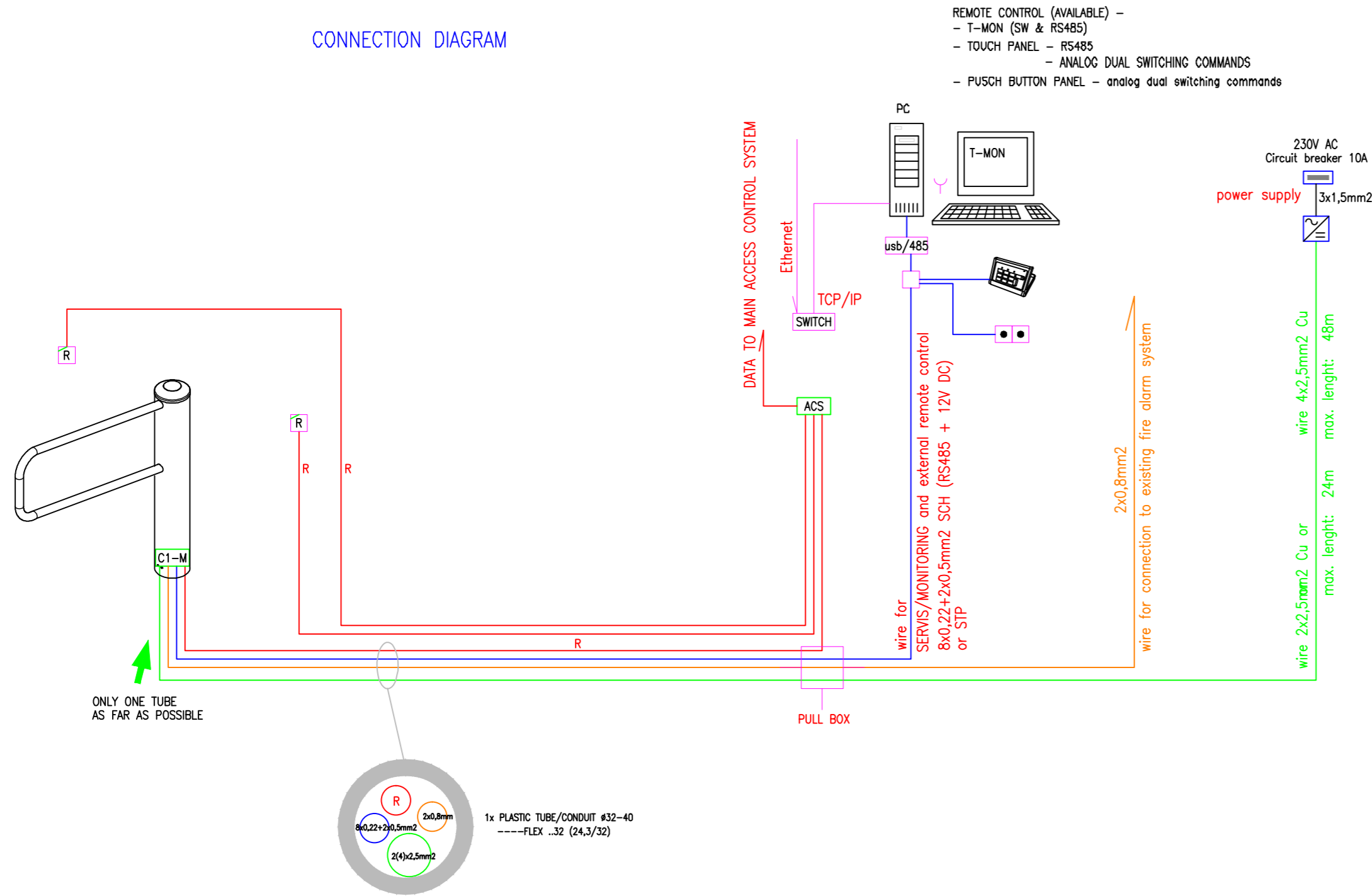

WIRING CONDUITS

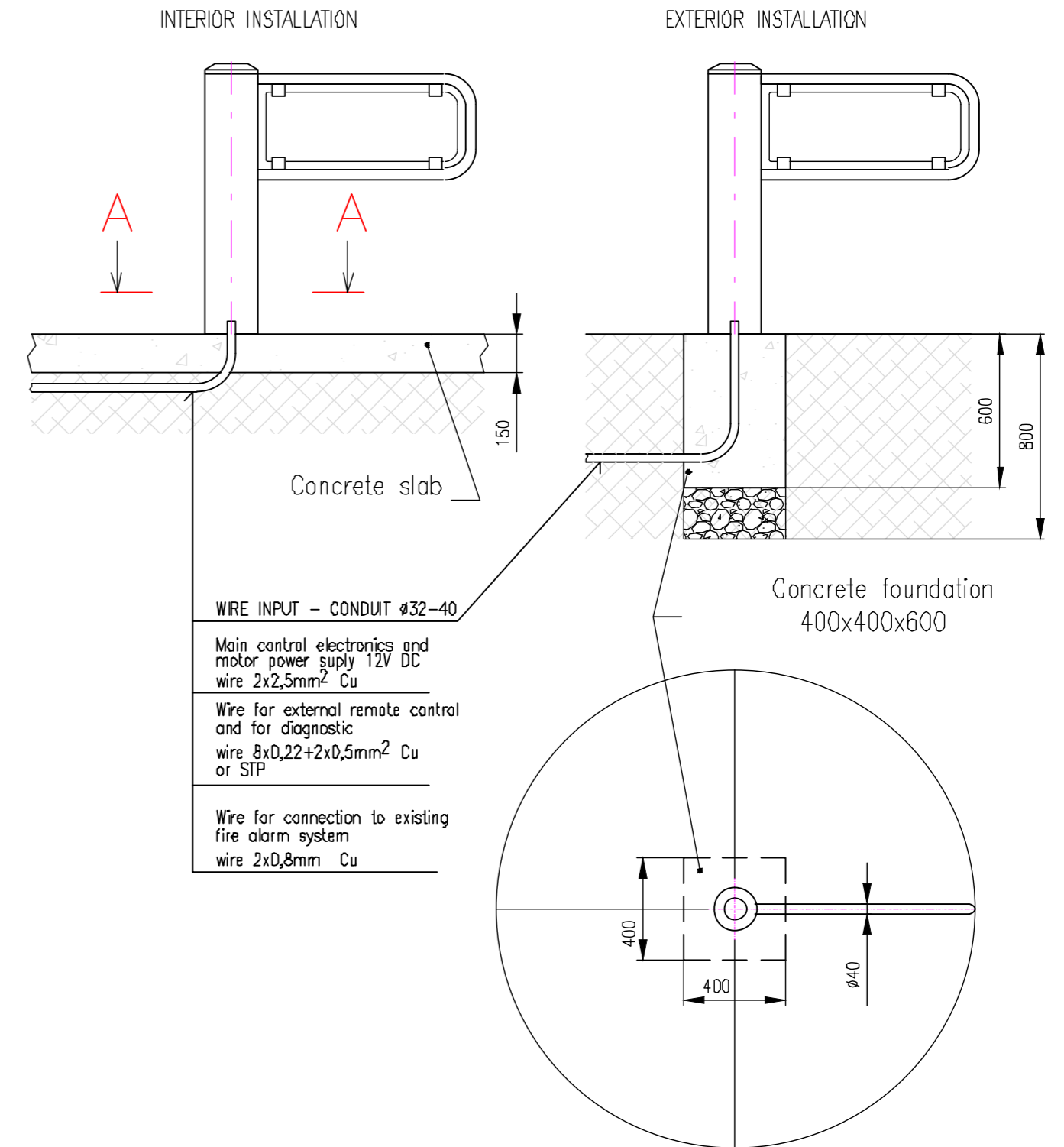

Gate: PEGAS-SF-S-204 (Glass: Connex 6,4mm)

ANCHORING GATE

Scale 1:2

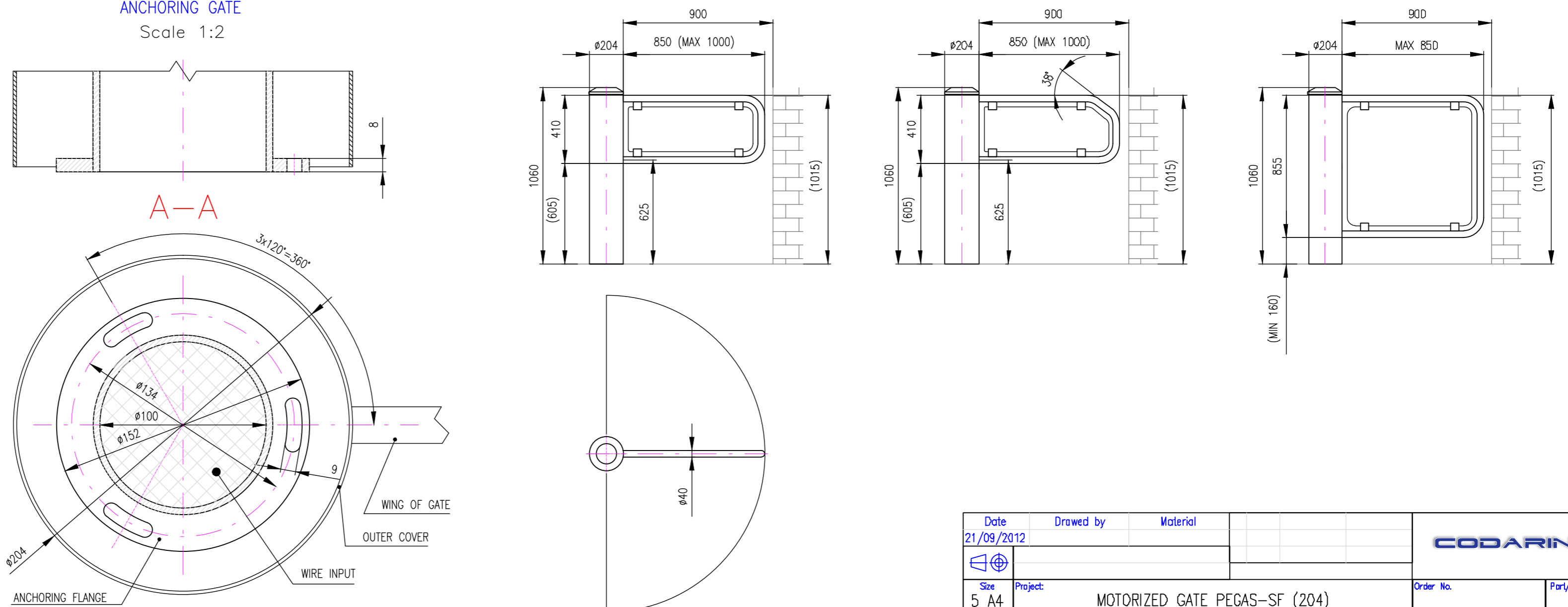

DRAWING SYMBOLS :

- MAIN CONTROL ELECTRONICS AND MOTOR OF P1 MOTORGATE
- POWER SUPPLY UNIT 230V AC/12V DC SELV, 3-7A (with BACK-UP ACCU)
- PULL BOX / CONNECTION BOX
- PUSCH BUTTON PANEL FOR EXTERNAL REMOTE CONTROL
- CONVERTER RS485/USB
- CONTROL ELECTRONICS OF READING DEVICES / READER CONTROL UNIT
- EXTERNAL READING DEVICE/ PROXIMITY RFID READER or BAR CODE READER
- ACCESS CONTROL CABLE
- TOUCH PANEL FOR EXTERNAL REMOTE CONTROL
- SWITCH OF PC NETWORK
- BOX 230V/50Hz
- OUTLET 230V 50Hz
- PC OUTLET - ETHERNET
- WIRE INPUT

Date	Drawn by	Material		
21/09/2012				
Size	Project	Order No.	Part/Parts	
5 A4	MOTORIZED GATE PEGAS-SF (204)			
Scale	Titre	D.No.	Version	
1:20	ANCHORING, WIRING, CONNECTIONS DIAGRAM	DC 120921-1		

CODARINI